

Advanced combustion technology  
for power and heat generation

**MORE** EFFICIENT ENERGY  
GENERATION





Securing a reliable energy supply is increasingly important for economic success. With DIEFFENBACHER as your partner, you can implement advanced power plant systems for efficient electricity and heat generation. The result is a plant tailored to your specific needs that can meet your energy requirements with various energy sources and fuels.

**How can we take your production and regional energy supply further?**

## CONTENT

### **1. Moving together toward efficient and sustainable energy solutions 4**

---

Minimum emissions, optimum efficiency: DIEFFENBACHER Energy provides customized power plant solutions. By working together, we can achieve the next level of sustainable energy supply for your business.

### **2. Bubbling fluidized bed 7**

---

High flexibility in fuel use, with low emissions: Reduce your fuel consumption with our bubbling fluidized bed combustion system.

### **3. Success stories bubbling fluidized bed 12**

---

Whether you need a complete power plant with complex water-steam connections or particularly demanding fuels: We take you one step further with our decades of experience.

### **4. Reciprocating grate 15**

---

Efficient combustion process, reduced CO<sub>2</sub> emissions: Optimize your energy generation with nearly total fuel combustion.

### **5. Success Story Reciprocating grate 19**

---

When the fuel quality fluctuates greatly or is heavily contaminated with stones: Optimize your energy production with our know-how.

### **6. Lifecycle management & service 21**

---

To maintain your power plant's maximum availability, we remain at your side with partner-based lifecycle support for both your own and third-party plants.

# 1. MOVING TOGETHER TOWARD EFFICIENT AND SUSTAINABLE ENERGY SOLUTIONS

---

## Achieve the next level of sustainable energy generation with DIEFFENBACHER at your side

- Customized concept development derived from comprehensive technological know-how
- Compliance with emission limits with low consumption of operating resources
- High flexibility due to high load-change speeds during plant operation
- Water-steam cycle optimized for maximum efficiency
- High fuel-choice flexibility
- High system availability

## Our employees' expertise is based on delivering more than:



**110**  
power plants

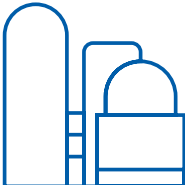

**2,700**  
process equipment components

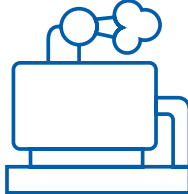

**90**  
heat recovery systems

\* Data as of 01/2023

## EXPERTISE AND TECHNOLOGIES FOR YOUR ENERGY GENERATION

Tap our years of experience and record of effective implementations of power plants, process equipment and heat recovery solutions to become more profitable. Our experts use their comprehensive engineering and manufacturing skills to successfully implement your energy project.



**To help you achieve your goals, we support you with:**

- Project development by technical experts, taking into account normative and legal requirements
- Plant design and engineering according to your specific requirements and site specifications
- Project and procurement management for smooth processes in compliance with the highest quality, safety and environmental protection standards
- Commissioning, including electrical grid connection and electrical switchgear integration
- Comprehensive lifecycle management

Minimal emissions and optimum efficiency: Realize your energy solution with us using advanced bubbling fluidized bed and reciprocating grate technologies.



## 2. BUBBLING FLUIDIZED BED

**Bubbling fluidized bed combustion system is the right choice for**

- Fuel particle sizes up to P100<sup>1</sup>
  - Biogenic residues
  - Waste fuels
- Co-firing of fine-grained fuels such as sawdust. These can be blown directly into the fluidized bed without a special dust burner.
- Wet or moist fuel (up to 60% water content)
- Very low calorific values (down to 4 MJ/kg)
- If a large calorific value range needs to be covered

<sup>1</sup>According to DIN EN ISO 17225-1

**Fuel suitable for bubbling fluidized bed combustion**



**Biogenic residues**

such as wood, waste wood (A1-A4), sawdust, chicken manure, etc.



**Agricultural waste**

such as olive pomace, shells, kernels, etc.



**Waste fuels**

such as rejects, fiber sludge, sewage sludge, RDF (Refuse Derived Fuel), etc.



**Lignin**

## DECISIVE ADVANTAGES OF AN ADVANCED BUBBLING FLUIDIZED BED BOILER SYSTEM

Achieve **greater flexibility** in fuels (calorific value band) derived from renewable raw materials while reducing CO<sub>2</sub> emissions. You can generate electricity and heat from biogenic residual and waste fuels, for example. This reduces your disposal and transportation costs, as the residual materials from your production processes are incinerated directly on site and converted into steam and electricity.

Our bubbling fluidized bed boiler systems contain a boiler-integrated bubbling fluidized bed with an open nozzle base. The bubbling fluidized bed is fluidized with a mixture of combustion air and recirculated flue gas. The fuel in the bubbling fluidized bed is converted sub-stoichiometrically. This allows the bed temperature to be precisely set and controlled regardless of the calorific value and load. This mode of operation significantly reduces nitrogen oxide emissions. Introducing the secondary air above the bubbling fluidized bed achieves complete combustion with low excess air for maximum efficiency. Our delivery spectrum ranges from individual power plant components to complete power plant solutions. We're your **reliable partner**, providing support from the initial planning stage through to the handover.

Due to our bubbling fluidized bed technology, you benefit from a high degree of flexibility in your fuel choice. Burning challenging fuels such as lignin and chicken manure with a **high level of efficiency** becomes possible. Read about our successful projects in the [Fluidized Bed Firing Success Stories](#) section.

Operate your DIEFFENBACHER Energy power plant efficiently, even with rapid consumer load changes. That's because our advanced firing capacity control quickly follows the load specification. Fast load-change capability is particularly important in heat-led processes. Load changes of  $\pm 5$  load %/min are the standard for our power plants. We have successfully implemented  $\pm 10$  load %/min for particularly high requirements in the 50-90% load range.

Operate your entire system more **efficiently** by reducing flue-gas losses: Due to the good mass and heat transfer in the bubbling fluidized bed, the excess air can be kept very low (4% O<sub>2</sub> humid) with low emissions at the same time.



Due to the heat stored in the bubbling fluidized bed, even **very wet fuels** such as fibrous and biological sludge can be burned. This extends the calorific value range down to 4 MJ/kg. Higher calorific fuels can also be burned in the same bubbling fluidized bed. Thanks to a controlled mixture of combustion air and recirculation gas, the fluidization and combustion conditions are automatically adapted to the respective fuel by the combustion capacity control during operation. This ensures optimal combustion conditions. Fuel flexibility with a bubbling fluidized bed combustion system ideally prepares you to accommodate future fuel changes due to fuel availability or market price fluctuations.

**High availability, lower maintenance costs:**

Your power plant with a bubbling fluidized bed furnace produces less wear in the combustion chamber, as there are no moving parts in the combustion system.

**Reduce investment costs:**

The fluidized bed has lower NOx emissions than a grate firing system due to the optimal combustion conditions. This reduces the costs for additives (urea, ammonia), and simpler, cheaper denitrification technologies can be used.

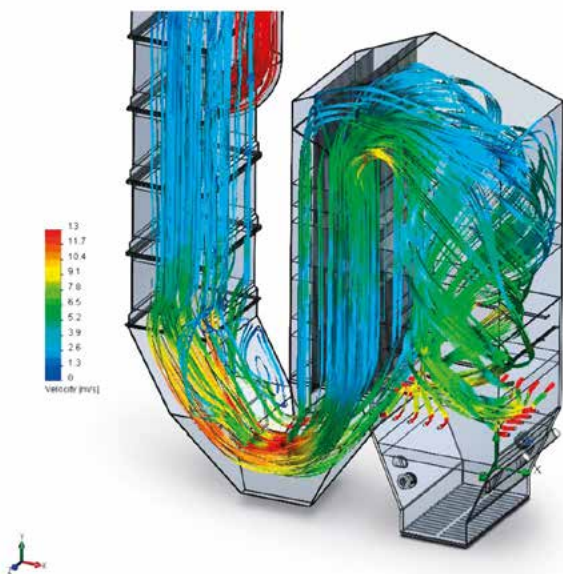

**Using the latest fluid dynamic simulations,** our experts achieve an optimal introduction of combustion air into the combustion chamber, complete combustion with low emissions and reliable achievement of the 2s residence time temperature >850°C required for waste.

## BUBBLING FLUIDIZED BED INTEGRATED IN BOILER

### Mixture of air and recirculation gas

for optimum fluidization conditions  
over the entire load range

### Staged combustion

through multi-stage  
secondary air injection

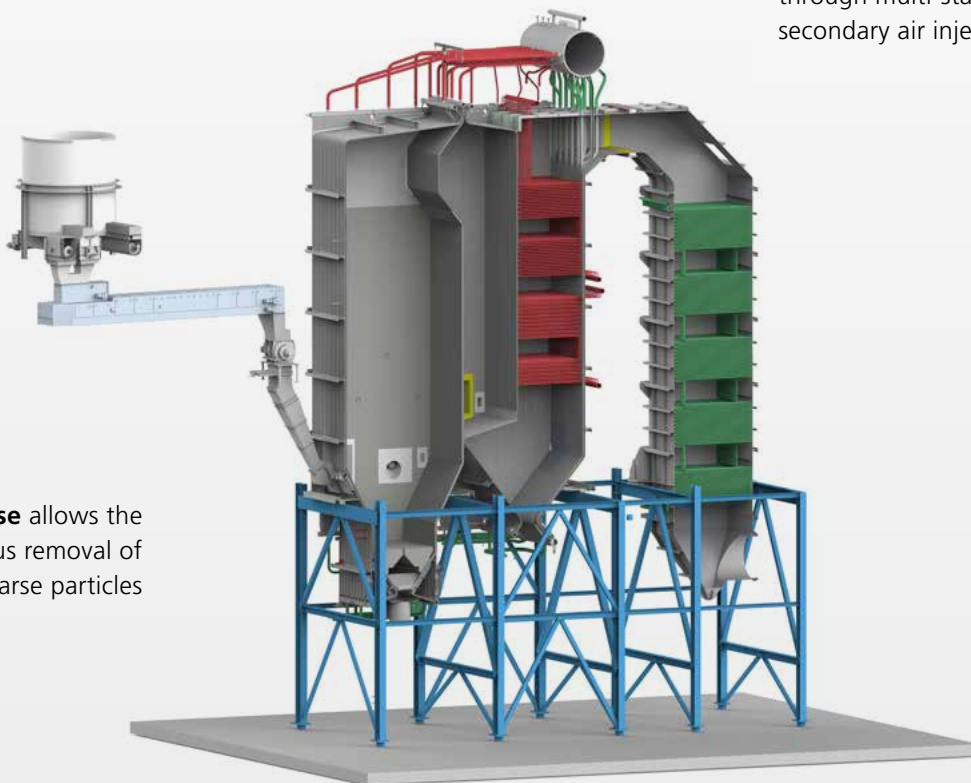

**Nozzle base** allows the  
continuous removal of  
coarse particles

**Continuous** bed material removal  
and bed material preparation to  
remove coarse particles

## ADVANTAGES OF BUBBLING FLUIDIZED BED COMBUSTION



**Lower emissions,**  
especially NO<sub>x</sub> and CO



**Longer cleaning intervals**  
(sootblower intervals) and, therefore,  
lower sootblower steam consumption



**Large fuel calorific value  
band**



**Co-combustion of fine-grained fuels**  
(e.g., grinding dust, sawdust, sawdust)  
without additional dust burner



**High availability and  
reliability**



**Co-combustion of wet fuels**  
(calorific value of the mixture >4 MJ/kg)



**Higher load change speed**  
compared to grate-firing  
systems



**Lower maintenance costs**  
as there are no moving parts in the  
combustion chamber



**Higher firing efficiency**  
due to lower excess air



**Highly efficient combustion of  
demanding fuels**  
such as lignin and chicken manure

### 3. SUCCESS STORIES: BUBBLING FLUIDIZED BED

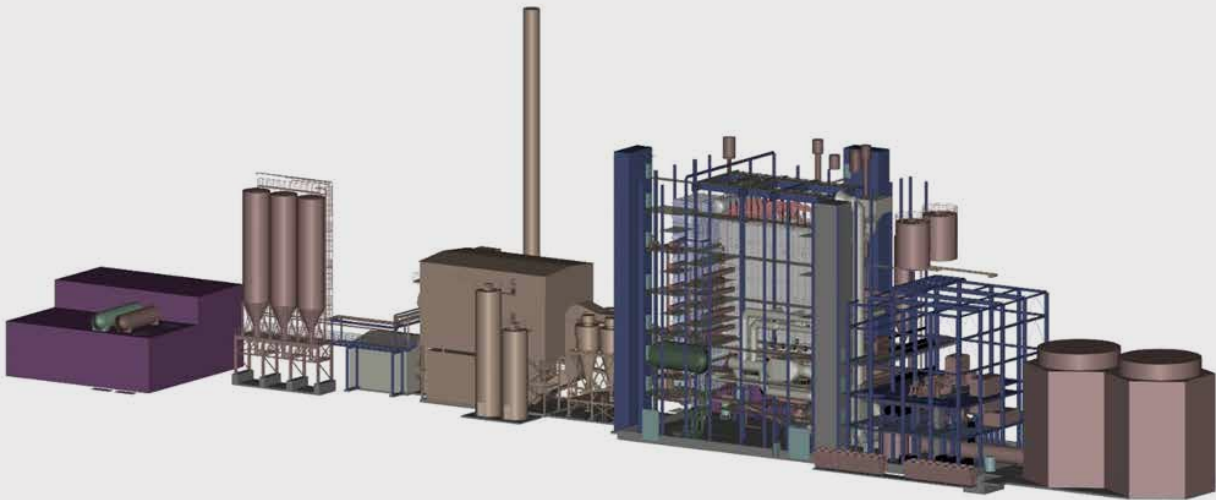

**A&U Wielsbeke**  
Belgium

#### **Power plant details and performance parameters**

**Fuels:** Waste wood A1-A4, wood dust (up to 50%), railroad ties (up to 5%)

**Fuel heat output:** 90.35 MW

**Live steam parameters:** 75 bar(a) / 463°C / 100 t/h

**Electrical output of steam turbine:** 20 MW

**Heat output thermal oil:** 10 MW

**Secondary steam thermal output:** 22 MW

**NOx emission:** 80 mg/Nm<sup>3</sup> @ 11%O<sub>2</sub>,dry yearly average value with SNCR (without SCR (catalytic converter)) at 13 mg/Nm<sup>3</sup> @ 11%O<sub>2</sub>,dry hourly average NH<sub>3</sub> slip

#### **Challenges:**

- Complete power plant with complex steam interconnections for the provision of secondary steam and thermal oil with maximum efficiency and simultaneous electricity production
- Very low NOx emissions only with SNCR denitrification

#### **Solution:**

- Bubbling fluidized bed combustion with low NOx emission values with complex water-steam cycle. Steam extraction directly from the boiler for thermal oil generation, bleed steam from the steam turbine for secondary steam generation
- Very high system availability of >99%



**99.5 MW bubbling fluidized bed boiler  
Turkey**

#### **Power plant details and performance parameters**

**Fuels:** Chicken manure

**Fuel thermal output:** 99.5 MW

**Live steam parameters:** 72 bar(a) / 473°C / 127 t/h

**Electrical output of steam turbine:** 34 MW

#### **Challenges:**

- Chicken manure is a demanding fuel: Due to the high alkali and ash content, this fuel leads to very heavy fouling of the boiler heating surfaces, which must be taken into account in the boiler design
- Very large plant: 99.5 MW fuel heat output and high installation altitude at 785 m above sea level
- High earthquake load

#### **Solutions:**

- Bubbling fluidized bed boiler with an efficient water-steam cycle for maximum electrical efficiency
- Tube cleaning system for the first and second boiler passes, sootblowers for the superheater heating surfaces in the third pass and a shot cleaning system for the economizer heating surfaces
- Large-dimensioned ash discharge and transport systems



## 4. RECIPROCATING GRATE

### Reciprocating grate firing is the right choice for

- Fuel particle sizes up to P200<sup>2</sup>
  - Untreated biomass
  - Waste wood
- For fuels of different sizes, for almost complete combustion
- Moist fuel with a moisture content of up to 150% atro (60% wet)

<sup>2</sup>According to DIN EN ISO 17225-1

### Fuel suitable for reciprocating grate



#### Biogenic residues

such as bark, wood and wood waste, W25-W60 (33-150% atro), etc.



#### Wood dust via dust burner



#### Prunings from landscape maintenance

Date palm leaves, etc.



## DECISIVE ADVANTAGES OF A RELIABLE RECIPROCATING GRATE

Use the **efficient combustion** process of a reciprocating grate for your energy generation: Individualized control of the grate zones ensures **almost complete fuel combustion**. Our grate systems are air-cooled and burn biogenic residues in one to three lanes, each divided into three to five zones. The primary air and recirculation gas supply and the grate bars' feed rate are controlled individually for each zone. We design and integrate grate sizes from 16-120 m<sup>2</sup>.

Reduce your **CO<sub>2</sub> emissions** and the use of fossil fuels: Generate sustainable electricity and heat from biogenic residues and waste materials and reduce your disposal and transportation costs simultaneously with your own DIEFFENBACHER Energy power plant.

In our grate systems, the reciprocating grate is either integrated into the combustion chamber of the natural circulation boiler or is used in refractory lined combustion chambers of process heat generators—for example, for the wood-based panel industry. As a **reliable partner**, we support you with everything from individual power plant components to complete power plant solutions, from initial planning to handover.



## RECIPROCATING GRATE IN REFRACTORY LINED COMBUSTION CHAMBER

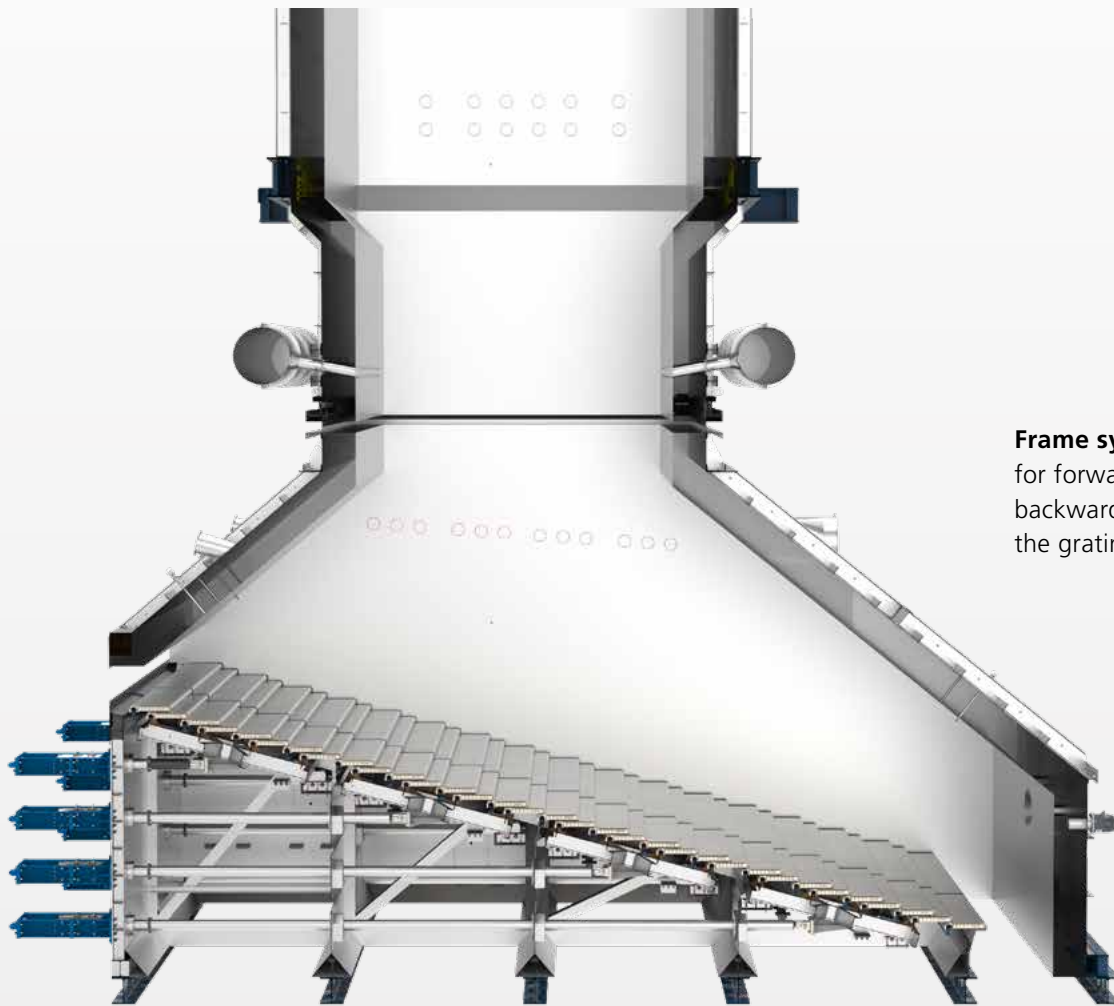

**Frame system**  
for forward and  
backward stroke of  
the grating bars

**Stiffened sheet metal partitions**  
underneath the grate to divide the zones  
for individual air supply

**Complete grate surface**  
consisting of fixed and movable,  
replaceable cast chrome grate bars

## ADVANTAGES OF RECIPROCATING GRATE COMBUSTION



**Lower pressure loss of the combustion air,** leading to lower power consumption



**Co-combustion** of wet fuels



**Dust burners and granulate nozzles compensate for load fluctuations**



**Suitable for hot,** recirculated flue gas under the grate



**Large fuel calorific value range** within the same plant



**Good accessibility** for maintenance and inspection



**High availability and reliability**



**Patented design** of the grate bars makes it easy to replace individual grate bars

## 5. SUCCESS STORIES: RECIPROCATING GRATE



**Camsan Ordu**  
Turkey

### **Power plant details and performance parameters**

**Process steam via thermal oil**

**Lined combustion chamber with large thermal oil heater**

**Firing capacity:** 65 MW

**Thermal oil output:** 39.5 MW

### **Challenges:**

- Regular fluctuations in the fuel posed a challenge when engineering this power plant. The grate had to extract the maximum energy from both very dry and very wet fuel. In addition, there was a high level of contamination with stones.
- Power plant was built in an earthquake-prone region, and the geological conditions had to be considered when planning for earthquake safety.
- Power plant was integrated into an existing facility.

### **Solutions:**

- Three thermal oil trains were connected in series to achieve the high required thermal oil output and simultaneously keep the flue-gas volume flow low.
- Thanks to careful 3D planning, the solution was able to be well integrated into the existing system while complying with all safety requirements.



## 6. LIFECYCLE MANAGEMENT AND SERVICE

---

### MAXIMUM POWER PLANT AVAILABILITY WITH PARTNERSHIP-BASED LIFETIME SERVICE

To ensure the maximum availability of your power plant, our highly qualified service personnel provide lifecycle support. The entire range of technical services applies to our own and third-party systems:

#### **Consulting**

- Mass and energy balances
- Thermal engineering calculations
- Process check
- Flow analyses
- Preliminary planning of revamp projects
- Advice on upcoming inspections and plant shutdowns

#### **Basic support**

- Recording and assessing the plant status
- Development of an extended maintenance strategy
- Development of improvement options

#### **Spare and wear parts management**

- Ensuring the availability of spare parts
- Plant-specific spare and wear parts

#### **Revamp and modernization**

- Replacement or adaptation of existing systems to changed framework conditions
- Simplification of existing system's operations

#### **Optimization**

- Projects for operational and plant optimization

#### **Repair**

- Root cause analysis and rectification
- Root cause analysis reports
- Restoring functionality

#### **Maintenance and inspection work**

- Checking the system for operational safety and functionality
- Systematic identification of potential faults
- Replacement with original spare parts

#### **Remote service**

- Advice on application and operating problems
- Telephone fault diagnosis and situation analysis
- System support via remote connection

## NOTES

---



## Discover how we can help you reach next-level energy efficiency

**DIEFFENBACHER Energy GmbH**, based in Bludenz, develops, designs and sells energy plants. As part of the DIEFFENBACHER Group, we offer advanced, energy-efficient and resource-saving solutions. In the energy-transition era, we also contribute to lower emissions and reduce energy costs.

**DIEFFENBACHER** is an international group of companies in the field of mechanical and plant engineering. With 1,850 employees and 19 production and sales locations worldwide, we are a leading manufacturer of press systems and complete production plants for the wood-based materials, automotive, aviation and recycling industries. We design and build power plants and heat recovery systems for sustainable energy generation. As an independent family business in its fifth generation, we have stood for reliable partnership and continuous progress for over 150 years.

### Your contact person

How can we help you move forward? Contact us.

#### **Sebastian Völker**

Chief Sales Officer

**sebastian.voelker@dieffenbacher.com**

**+43 5552 6135 572**

#### **DIEFFENBACHER ENERGY GmbH**

Untersteinstraße 4

6700 Bludenz

Austria

[www.dieffenbacher.com/en/energy](http://www.dieffenbacher.com/en/energy)

